

MGL Avionics

V16 Aviation band transceiver

User and Installation manual



Table of Contents

RF Exposure.....	4
FCC Statement.....	4
General.....	4
Document history.....	4
Description.....	4
The Transmitter.....	4
The Receiver	5
The intercom system.....	6
RX playback feature.....	6
Power supply.....	6
Antenna.....	7
Digital control interfaces.....	7
Applicable standards.....	7
Specification table.....	8
General specifications.....	8
Audio input specifications.....	9
Audio output specifications.....	9
Audio, RX and TX filters.....	10
Transmitter self protection.....	10
Transmitter low power option.....	10
Environmental qualification matrix.....	11
V16 Connector pinout.....	13
Typical connection diagrams.....	15
Audio wiring.....	15
Audio signal wiring advice.....	15
Control heads and options.....	16
Pinout for 3.18" Razor and 2.25" Vega transceiver control head.....	16
V16 with one or more control heads.....	17
V16 with a MGL Avionics EFIS system.....	17
V16 plus N16 Navigation receiver.....	17
V16 plus N16 with one or more control heads.....	18
Electrical state interfaces.....	18
PTT inputs.....	18
Intercom Switch/Playback switch.....	18
TX Interlock.....	18
RF feedback – cause and elimination.....	19
TX signal delay.....	19
RS232 and CAN bus communication protocols.....	19
Setup menu.....	20
Menu items.....	20
CAN bus addressing.....	22
VSWR Antenna checks and tuning.....	22
What is a good antenna match ?.....	22
Reasons for a bad VSWR:.....	23
Tuning antennas.....	23
Mechanical dimensions.....	24

RF Exposure

This Transceiver generates RF electromagnetic energy while transmitting. For compliance with RF exposure limits, the antenna gain should not exceed 0dBd (dipole antenna) and any persons should maintain a distance of at least 1m/3ft from the antenna during operation.

Do not operate this Transceiver in an explosive atmosphere.

FCC Statement

THIS DEVICE COMPLIES WITH PART 15 OF THE FCC RULES. OPERATION IS SUBJECT TO THE FOLLOWING TWO CONDITIONS: (1) THIS DEVICE MAY NOT CAUSE HARMFUL INTERFERENCE, AND (2) THIS DEVICE MUST ACCEPT ANY INTERFERENCE RECEIVED, INCLUDING INTERFERENCE THAT MAY CAUSE UNDESIRE OPERATION. FCC ID: **2ANEFV16**

NOTE: THE **GRANTEE** IS NOT RESPONSIBLE FOR ANY CHANGES OR MODIFICATIONS NOT EXPRESSLY APPROVED BY THE PARTY RESPONSIBLE FOR COMPLIANCE. SUCH MODIFICATIONS COULD VOID THE USER'S AUTHORITY TO OPERATE THE EQUIPMENT.

General

This manual documents the installation and use of the V16 air band transceiver. Please note that operation of the transceiver with respect to settings such as frequency, volume etc is done by the connected control panel. User interface varies by type of connected system. Please refer to documentation for the connected equipment for details.

This manual describes available settings through the connected equipment in a generic way that is applicable to all types.

Document history

1 November 2017, first release.

11 January 2018, added information on TX power tolerance and modulation characteristics.

Description

The V16 airband transceiver is a split module consisting out of the transceiver body and optional external control. External control can take the form of one or more panel mount control heads and/or control by an EFIS system.

The Transmitter

The transmitter is designed to deliver a 10W un-modulated carrier into a 50 ohm matched antenna load. Modulation is controlled fully digitally to achieve to 70% modulation index by means of asymmetric gain control of the modulating audio signal. This permits ideal use of available carrier power while providing a very power efficient transmitter with low heat generation, while at the same time maximizing range.

The modulator is realized as a class-D circuit greatly adding to the overall power efficiency of this design.

An optional transmit interlock output/input is provided which may be used in systems employing two transmitters from preventing simultaneous transmissions.

Two PTT inputs are provided, one for each intercom input. If desired, these inputs may be joined into a single PTT switch.

The transmitter fulfills the bandwidth requirements for both 25Khz and 8.33Khz channel spacing operations.

The Receiver

The receiver is implemented as a direct conversion architecture. The signal to be received is converted directly to audio baseband using a dual receiver chain with two identical receivers. One of these produces a slightly delayed signal. These signals are known as I and Q. They are then converted into digital using very high quality 24 bit converters and all further signal processing takes place in a high performance processor. Here the original carrier is recreated from the I/Q signals and following extensive processing the audio signal is recovered from the carrier while unwanted signals are rejected.

In order to meet latest ICAO requirements for FM band immunity the receiver employs a surface acoustic wave RF filter before any active amplification to reject any out of band signals before they can inter-modulate with wanted signals. The overall receiver architecture is designed to be able to handle very strong in band and out of band signals while managing at the same time to provide good sensitivity to very weak signals.

The Receiver is designed to be able to operate in any currently known receiver class within the 25Khz and 8.33Khz channel spacing systems including offset carrier operations.

The Receiver can be operated in scanning mode. In this mode both main and standby frequencies are monitored. If a signal is received on main frequency (as determined by RX squelch opening) that signal is routed through and no scanning of the standby frequency takes place for the duration of the RX.

If a signal is received on the standby frequency, this signal is routed through. However, the main frequency is monitored several times per second. Should a transmission be received on the main frequency while there is a transmission being received on the standby frequency the receiver will immediately switch to the main frequency.

Monitoring the main frequency while receiving a signal on the standby frequency results in very short breaks in the received audio (while the main channel is quickly checked). These breaks last only a few milliseconds and do not result in loss of audibility of the received signal. In order to further improve on this the receiver fills the short gaps with audio signal received immediately prior to the switch over. This tends to mask the gaps almost completely.

The receiver includes a permanently enabled impulse noise suppressor implemented using digital signal processing algorithms. This system detects impulse noise on the received carrier frequency such as typically caused by ignition systems or other interference sources. As this noise has distinct characteristics it can be removed from the received signal, in many cases without leaving a trace.

Note that despite this the actual sensitivity of your V16 may still be reduced by interference.

The impulse noise suppressor however helps greatly in removing the audible effects of this interference.

The intercom system

A two place VOX intercom system is provided. The intercom is implemented fully digital using a 24 bit audio codec and achieves excellent audio quality. Microphone gain adjustment is provided that operates over an unusually large range allowing great flexibility in choosing compatible headsets and microphones. The microphone inputs provide a 8V DC bias for standard aviation headset pre-amplifiers.

VOX level is adjustable over a wide range.

In addition it is possible to use the “intercom” input connected to a switch to “open” or “close” the intercom in applications where the VOX system is not suitable.

One auxiliary input is provided with two gain settings. This allows muting the input to a lower level (or switch it off) if voice activity is detected on either microphone input. The input is suitable for use with mobile phones, MP3 music players or audio annunciators from EFIS systems.

The audio output can drive a 8 ohm speaker up to 0.5W for base station use. In such a case it is recommended to switch the side tone “off” in the setup to prevent audio feedback from speaker to microphone.

RX playback feature

The Receiver has a very useful feature that records up to a minutes worth of received audio in high quality. Only signals that open the squelch are recorded. The available storage can be spread over several received transmissions in a first in last out fashion.

Recall of a last received transmission can be achieved in several ways:

By configuration of the “intercom” switch as “RX audio recall” in the setup. You can then use a push button on the stick for example to easily recall a last reception.

By using a function provided in an attached control head or EFIS system. This may also be activated by a button connected to such equipment in some cases.

To recall the last RX, simply push the button once. To recall the previous RX to this, press the button again while the last RX is playing back. Repeat this for all recorded signals.

If you allow a recorded message to finish playback, pressing the button will again start with the last recorded message.

Note: Any reception lasting less than one second will not be recorded (these are usually “nuisance” squelch breaks due to a short transient signal).

Note: If squelch is open all the time (squelch value “0”) no recording takes place.

Power supply

The V16 airband transceiver is designed to be operated on a typical 12V DC aircraft power system. The DC supply must be free of undesired transients and reasonably stable within the acceptable supply voltage range of the V16.

It is possible to operate the V16 on 24/28V DC power supplies as well.

For operation with compromised power sources on aircraft it is advised to consider external power conditioning such as the MGL Avionics AvioGuard isolated power supply.

Antenna

The V16 airband transceiver is designed to operate with standard 50 ohm impedance aircraft VHF antennas.

The modular nature of the V16 allows placement of the V16 closer to the antenna, reducing antenna cable length and losses.

A built in SWR meter provides information on RF power at the connector and reflected power from the antenna as a ratio. Depending on the connected control equipment this information may be displayed in a diagnostics mode or during every transmission.

The antenna connector provides a DC isolated path to the antenna. This includes the cable sheath. This means there is no possibility of a DC current path from aircraft skin via antenna and cable through the radio. This protects the radio against ground faults and prevents ground loops.

Digital control interfaces

The V16 airband transceiver provides two RS232 ports as well as a CAN bus interface.

The CAN bus is typically used with control heads from MGL Avionics.

RS232 port 1 may be used with EFIS systems. RS232 port 2 is not currently used.

Applicable standards

The V16 airband transceiver meets or improves on the following standards:

ETSO 2C169a VHF Radio communication receiving equipment operating within the radio frequency range 117.875 – 137 MHz

TSO C169a Minimum Operational Performance standards for Airborne Radio Communications equipment standards

ETSO 2C128 Devices that prevent blocked channels used in two-way radio communications due to unintentional transmissions

TSO C128a Equipment that prevents blocked channels used in two-way radio communications due to unintentional transmissions

FCC Part 87 Aviation Services (airborne and fixed ground stations)

FCC Part 15 radiated emissions

With reference to:

ICAO Annex 10 as amended.

Specification table

General specifications

Compliance	ETSO 2C169a Class C, E, H1, H2, 4, 6, ETSO 2C128, TSO C169a Class C, E, 4, 6, TSO C128a
FCC Identification	2ANEFV16
Documents	EUROCAE ED-23C, EUROCAE ED-67, EUROCAE ED-14F RTCA DO-160F, RTCA DO-186B, RTCA DO-207
Software	Software ED-12B RTCA DO-178B Level C
Supply voltage	10-28VDC, DO-160 surge limiter active at 34V and higher.
Supply current	RX: 0.3A at 13.8V, TX: 2.5A at 13.8V, TX into 50 ohm dummy load.
Operating temperature	-20 to +55 degrees Celsius. Convection or forced air cooling recommended if operated regularly at high ambient temperatures.
Frequency range	118.000 MHz to 136.992 MHz, 25Khz and 8.33Khz channel spacing. Compatible with offset carrier operations with either channel spacing.
TX Power	High power option selected: 10W @13.8V, 8W @ 12V, 6W @ 10V Low power option selected: 5W at any voltage above 9V. Tolerance: +/-15%. Note: Due to the asymmetric modulation scheme that aims to reduce peak power needs, when modulated with a constant tone at maximum modulation index average power will show a slight decrease when measured with typical power meters. This decrease may be up to 10% depending on signal characteristics.
Modulation	AM 5K6A3E, Modulation is digitally controlled to achieve a modulation index of 70%, hard limited to a maximum of 80%. Modulation depth is regulated independently for positive and negative waves.
Undesired out of channel TX products	<-60db referred to unmodulated carrier at maximum power
Stuck PTT timeout	35 seconds
RX sensitivity	-107dbm @ 127Mhz for +6db S+N/N, 30% modulation, 1Khz, (0.3-2.9Khz bandwidth) -109dbm for 8.33Khz channels (0.3-2.4Khz bandwidth)
RX Large signal	+9dbm @127Mhz, off-channel blockers >+15dbm
RX audio unwanted signals including distortion products	Less than -50db referred to 30% modulated carrier typical up to large signal limit.
Adjacent channel	>80db typical

suppression	
LO leakage into antenna connector	<-100dbm
RX bandwidths	21Khz @ 25Khz spacing, 7.6 Khz @ 8.33Khz spacing (offset carrier possible on either 25Khz or 8.33Khz according to ICAO recommendations)
RX Squelch	Manual level with automatic adjustment within fixed range of manual setting. Adjustment range: Off + -100dbm to -70dbm in 32 steps.
Audio RX recording time	Approximately 1 minute of combined active RX (multiple RX message storage and playback). Audio compression 16 bit ADPCM @ 16Khz.
Digital audio	I/Q sampling: 24 bits @ 32Khz, Audio: 24Bits @ 16Khz
Weights	300 grams, complete unit. 120 grams, functional PCB with shielding plate excluding housing (as OEM module for integration into third party systems)
Dimensions	Mounted height 31mm Width 88mm Depth (including flanges) 167mm Depth (excluding flanges) 142mm

Audio input specifications

Microphone inputs	Gain range -12db to +35.25db	At -12db, input voltage of 1.5Vpp clips At +35.25db input voltage of 20mVpp clips Typical gain setting for aviation headset: +12db Input impedance 240 ohms A/C. 8V DC microphone bias via 470 ohms.
Auxiliary input	Gain range -15db to +6db	Maximum input level 2Vpp Typical level required for normal volume at +6db is 100mVpp. Input impedance 47KOhm.

Audio output specifications

Output impedance	8 ohms. Suitable for connection of high impedance headphones.
Output power	0.2W low distortion. Up to 0.5W at 1% distortion.
Maximum voltage swing	5Vpp (1W into 8 ohms) 6.5Vpp into 300 ohms
Typical voltage swing for 600 ohm aviation headsets	1Vpp-2Vpp

Frequency response audio power amplifier	200Hz to 20Khz at 8 ohms load, lower limit decreases with lower loading (100uF output coupling capacitor)
Volume control range	32 steps of 3db each. Total control range = 96db.

Notes: V16 can be operated with RX and Intercom volume set as one or these can be split into separate volume controls. This depends on the corrected heads or control system.

In case of split operations, the above table applies for both audio sources.

Audio, RX and TX filters

Microphone inputs Pilot and PAX	350-2900Hz, Butterworth 4 pole BP
TX modulator 25Khz	0-2900Hz, Butterworth 4 pole LP
TX modulator 8.33Khz	0-2400Hz, Butterworth 4 pole LP
AGC	0-5Hz, Bessel 4 pole LP, step response 0.1 second to 95% of final value.
RX audio 25Khz	200-2900Hz, Butterworth 4 pole BP
RX audio 8.33Khz	200-2400Hz, Butterworth 4 pole BP
Channel filter 25Khz	0-10500Hz, Butterworth 8 pole LP + 3 pole R/C LP at ~15Khz
Channel filter 8.33Khz	0-3900Hz, Butterworth 8 pole LP + 3 pole R/C LP at ~15Khz
RX anti aliasing	16Khz FIR > 60db stop band (adds to channel filtering)
Sidetone audio filter	0-2900Hz, Butterworth 4 pole LP

Transmitter self protection

The transmitter is designed to derate output power if:

a) Temperature in the immediate surrounding of the output power transistor exceeds 90 degrees Celsius. Maximum temperature derating of power is 50% and this is reached at a temperature of 100 degrees Celsius.

b) VSWR exceeds a value of 3.0. Power will be linearly reduced up to a maximum of 50% reduction which is reached at a VSWR value of 5.0 (44% reflected power from antenna).

Maximum total power derating is 50%, i.e. 5W unmodulated carrier at 13.8V DC supply.

Transmitter low power option

For applications not requiring nominal TX power it is possible to select to reduce carrier power by 50% (5W unmodulated carrier).

This reduces electrical power consumption during TX by approximately 40%. This option may also be helpful in compromised installations to reduce RF feedback issues during TX.

Environmental qualification matrix

The environmental qualification is based on the document DO-160G

Temperature and Altitude	4.0	Equipment Categories B2, C1	
Low temperature ground survival	4.5.1	-50°C	
Low temperature shorttime operating	4.5.1	-30°C	
Low temperature operating	4.5.2	-20°C	
High temperature operating	4.5.4	+55°C	
High temperature shorttime operating	4.5.3	+65°C	
High temperature ground survival	4.5.3	+85°C	
Loss of Cooling	4.5.5	Cooling air not required	Convection cooling or forced air cooling recommended in compromised installations.
Altitude	4.6.1	55,000 feet	
Decompression	4.6.2	8,000 to 55,000 feet in 15 seconds	
Over pressure	4.6.3	-15,000 feet	
Temperature Variation	5.0	Equipment Category B	
Humidity	6.0	Equipment Category A	
Operational Shocks	7.2	Equipment Category B	
Crash Safety	7.3	Equipment Category B Type 5	
Vibration	8.0	Aircraft zone 2; type 3, 4, 5 to category S level M, type 1 (Helicopters) to category U level G	
Explosion	9.0	Equipment identified as Category X	

		– no test required	
Waterproofness	10.0	Equipment identified as Category X – no test required	
Fluids Susceptibility	11.0	Equipment identified as Category X – no test required	
Sand and Dust	12.0	Equipment identified as Category X – no test required	
Fungus	13.0	Equipment identified as Category X – no test required	
Salt Spray	14.0	Equipment identified as Category X – no test required	
Magnetic Effect	15.0	Equipment tested to Category Z, safe distance 20cm	
Power Input	16.0	Equipment Category BXX	
Voltage Spike	17.0	Equipment Category B	
Audio frequency conducted susceptibility	18.0	Equipment Category B	
Induced signal susceptibility	19.0	Equipment Category AC	
Radio frequency susceptibility	20.0	Equipment Category TT	
Radio frequency emission	21.0	Equipment Category B	
Lightning induced transient susceptibility	22.0	Equipment identified as Category B2G2L2 – no test required	
Lightning direct effects	23.0	Equipment identified as Category X – no test required	
Icing	24.0	Equipment identified as Category X – no test required	
Electrostatic Discharge	25.0	Equipment identified as Category X – no test required	
Fire, Flammability	26.0	Equipment identified as Category C	

Notes: Power input tests chapter 16. The V16 easily complies with all required criteria. The V16 has a limitation related to power supply voltage rise time which falls well outside of any required performance standards. Voltage rises from 0 to about 2.0V at any rate and then the rise time to about 3.6V is very slow (in the region of greater than about 0.5 seconds) the V16 will enter self protection mode which will only be released when voltage drops again below 2.0V. In this mode the internal processor will lock itself and its integrated memories out for protection against damage by pre-start brownout conditions. This limitation does not apply if the V16 is already up and running and voltage dips not lower than 2.0V before rising again slowly as the critical startup time does not apply in this case due to a secondary brownout detection being active at this time.

The processor, should it enter self protection mode, will release this mode on the next power cycle provided voltage ramp up is faster than the maximum time of 0.5 seconds in the mentioned voltage range.

This limitation however is unlikely to affect any real world applications and is mentioned only for completeness sake.

The V16 is designed not to commence operation until supply voltage reaches about 7V on startup regardless of the above condition. Once operating, the V16 will continue to operate in receive mode down to about 6V (for transmit to be allowed a minimum supply voltage of 10V needs to be present and voltage must not drop below 9V during transmit).

The above measures have been included to prevent any internal hardware damage due to unusual supply voltage conditions during low to very low voltage conditions.

V16 Connector pinout

1	Headphone audio (speaker output). Suitable for connection of multiple 600 ohm aviation headsets or a 8 ohm impedance (minimum) speaker.
2	audio output ground
3	CAN-H Communications interface to a compatible MGL control head
4	CAN-L As above
5	RS232 RX 1 Communications interface to an MGL EFIS system
6	RS232 TX 1 As above
7	RS232 RX 2 Not used, do not connect
8	RS232 TX 2 Not used, do not connect
9	Audio input ground
10	Pilot microphone
11	Audio input ground
12	PAX microphone
13	Audio input ground
14	PTT Pilot
15	PTT and intercom switch ground

16	PTT PAX
17	Intercom switch or RX audio playback (selected by configuration)
18	TX Interlock - connect to corresponding pin on second V16 transceiver
19	Auxiliary audio ground
20	Auxiliary audio input (Music, EFIS, mobile phone etc)
21	Programming pin. Leave this pin unconnected
22	Power supply ground
23	Power supply ground (connected internally to pin 22)
24	+12V to +28V DC power supply input
25	+12V to +28V DC power supply input (connected internally to pin 24)

Typical connection diagrams

Audio wiring

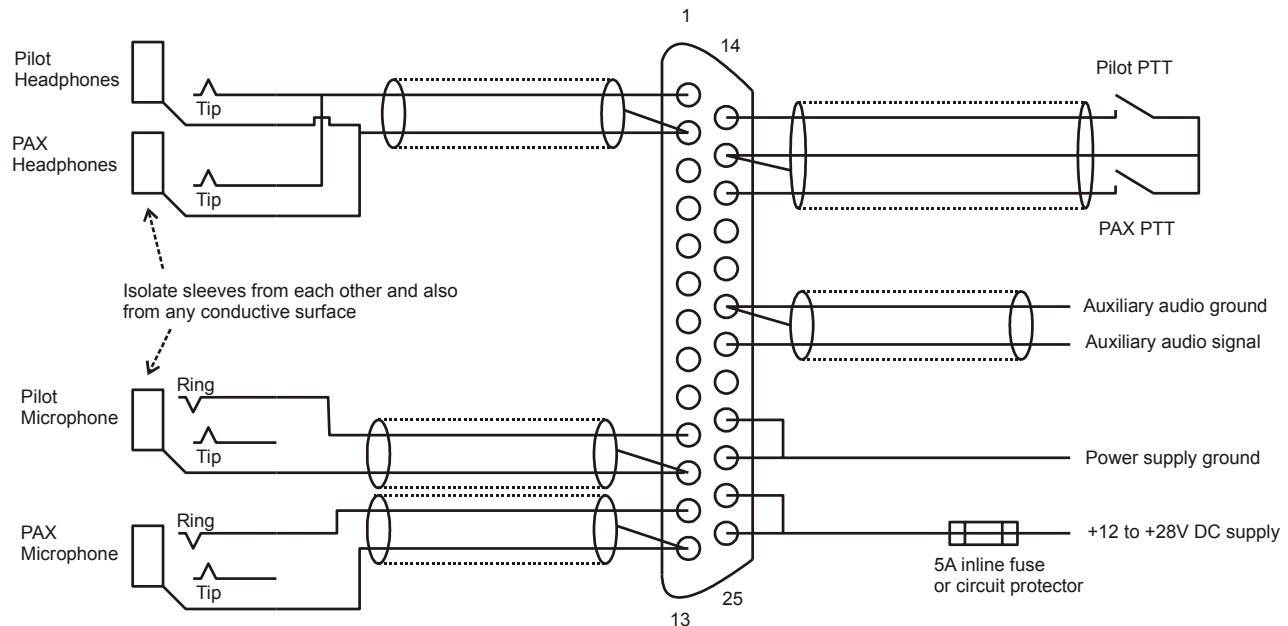

This diagram shows a typical two place setup for a pilot and single passenger for two headsets.

In this example, two PTT switches are used. If the Pilot PTT is activated, only the pilot voice is transmitted and the passenger voice is muted.

If the passenger PTT is activated, only the passenger voice is transmitted and the pilot is muted.

If both PTT switches are activated at the same time, both pilot and passenger voices are transmitted.

Variations to the example: Wire only the pilot PTT switch if no passenger PTT is required, leave the passenger PTT pin unconnected.

Alternative: Connect both pilot and passenger PTT pins together to a single PTT switch. In this case activation of the switch will transmit both pilot and passenger voices.

Audio signal wiring advice

It is strongly advised to use good quality shielded audio cable. The diagram shows that all shields are connected on **only one side**. Shields are never used to conduct signals.

Signal grounds have their own wire inside the shielded cable (you would be using a two core plus shield cable).

NEVER run the audio output signals together with the microphone signals inside the same shielded cable. This may result in feedback effects.

Avoid running any audio cable next to cables that may contain interference signals. It is good wiring practice to run audio cables in their own bundles.

Never run any cables (audio, signal or otherwise) close to the antenna cable.

If using audio and microphone sockets please ensure that these are electrically isolated from each other as well as from any conduction material such as a panel, metal box, bracket etc. If the sleeves are not isolated it is likely undesirable audio interference may occur in particular during transmit.

Control heads and options

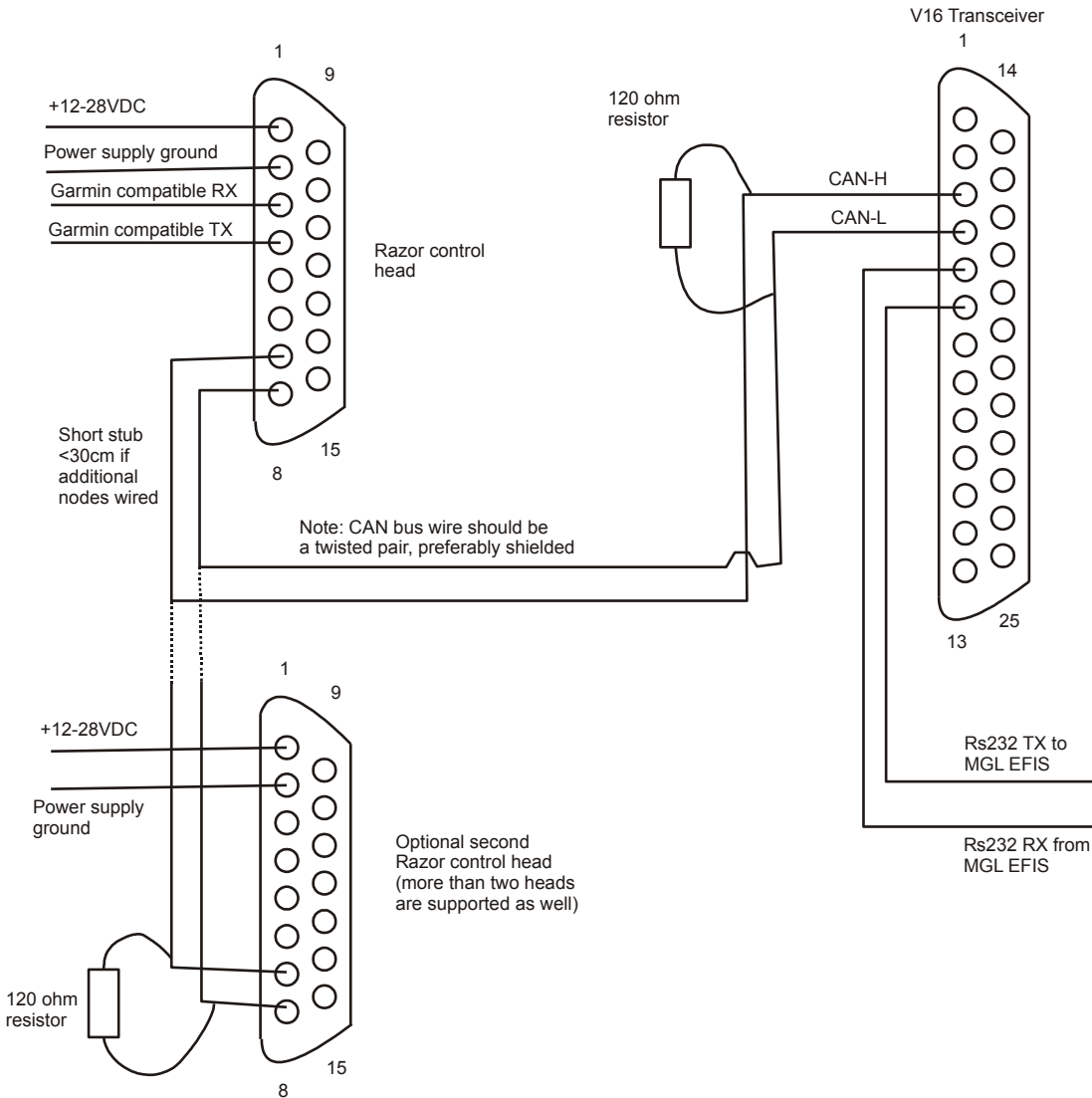

The V16 transceiver module must be connected to at least one controller. It is possible to operate the V16 without a control head if one has been used to setup volume and other settings. In this case only a single frequency is used (setup by the control head). All settings are stored in the V16 and maintained. This is an option for fixed base station use only.

Pinout for 3.18" Razor and 2.25" Vega transceiver control head

1	Supply +9 to +28VDC
---	---------------------

2	Supply ground
3	RS232 RX Port 1
4	RS232 TX Port 1
5	RS232 RX Port 2
6	RS232 TX Port 2
7	CAN H (connect to CAN H on transceiver and NAV radio)
8	CAN L (connect to CAN L on transceiver and NAV radio)
9	Ground (Internally connected to pin 2)
10	KeepAlive. Do not connect.
11	A1. Control input. Select desired function in Razor setup menu.
12	A2. Control input. Select desired function in Razor setup menu.
13	Program pin. Do not connect.
14	USB P. Do not connect
15	USB M. Do not connect.

V16 with one or more control heads

Either a 3.18" or 2.25" head may be used. The head is connected to the V16 using the CAN bus.

The head provides a RS232 bus that implements Garmin compatible interface for use by third party systems.

Multiple control heads may be connected to the V16 if desired.

V16 with a MGL Avionics EFIS system

The V16 is connected via RS232 port number 1 to the chosen port on the EFIS. Configure the EFIS for a MGL COM radio. Connect RX to TX and TX to RX. On the other end. Use of shielded cable is recommended. Do NOT connect a ground between V16 and EFIS if both are supplied from the same supply as this will create a ground loop that can invite interference.

Note: It is possible to connect a V16 to the EFIS and at the same time to one or more control heads via the CAN bus.

V16 plus N16 Navigation receiver

The V16 can be combined with a N16 navigation receiver that provides VOR, ILS and glideslope information.

Both V16 and N16 are connected via CAN bus and optionally to one or more control heads.

This effectively turns the V16 and N16 into a single NAV/COM solution.

The connection to an MGL EFIS remains on the V16 RS232 port number 1. In this case the information from the N16 received via CAN bus is forwarded to the EFIS on the same RS232 port.

V16 plus N16 with one or more control heads

If the V16 and N16 is connected via CAN bus to any control head, that heads RS232 port number 1 acts as a Garmin NAV/COM compatible communications port.

Note: This also works if the V16 and N16 is connected to an MGL EFIS via the V16 RS232 port number one at the same time.

Electrical state interfaces

PTT inputs

PTT inputs are realized as active low digital inputs with internal 2200 ohm pull up resistor to 3.3 Volts feeding the base of a transistor via a 10.000 ohm resistor. Open circuit voltage is approximately 3V. PTT is activated when the voltage is pulled by an external device such as a switch below about 0.8V.

It is common to connect a PTT switch to ground. The switch is closed when PTT is active.

The PTT input has a RF filter consisting of a ferrite bead feeding into a grounded capacitor.

Intercom Switch/Playback switch

The intercom switch input is realized identical to the PTT inputs. Active state is pulled low.

TX Interlock

The TX interlock is both input as well as output. It is realized as input with a pull up of 2200 ohm to 3.3Volts similar to the PTT inputs but also has an output transistor that can switch this output to ground.

The TX interlock is grounded by the internal transistor whenever the transmitter is active. Should this line be grounded by an external device while the transmitter is not active, the PTT inputs as well as PTT commands from the communications interfaces are disabled.

If the TX interlock is grounded by an external device while the transmitter is active it will not have any effect on the current transmission.

It is common to connect this line to the corresponding TX Interlock of a second V16 to prevent simultaneous transmissions.

An alternate use of the TX interlock is to enable an external RF power amplifier during TX for ground station use if higher TX power is desired. In this case, if the TX Interlock is at a level of 3.0Volts the power amplifier is disabled and the antenna is switched through to the V16 receiver directly.

RF feedback – cause and elimination

RF feedback is a phenomena very similar to microphone feedback on a sound stage. The modulated RF signal during transmission is received by your microphones or microphone cables and routed to the input of your intercom system or V16 transceiver.

Here, some of the modulated signal may be demodulated by non-linearities in the system, particularly if the received RF is very strong (typically several volts).

This creates a common feedback loop that in a mild form will create an echo similar to “bathroom sound” and in severer cases will cause squealing or other undesirable effects.

One of the most common causes for this is missing microphone cable shields due to broken wires or poor quality or unsuitable microphone cables.

Sometimes very close proximity of the transmitting antenna to headsets or other aircraft wiring may be the cause.

In difficult cases, use of ferrite beads placed at strategic locations over your microphone and headset cables may help block RF from traveling on these cables. Ensure you use ferrites made to operate in the 100-150Mhz frequency band for this to be effective.

Never route your antenna cable inside a bundle with other wires in your aircraft. Keep your antenna cable well separated from all other cables.

One of the prime causes of RF feedback is a badly matched antenna. Your V16 contains a full feature SWR meter which you can use to check your antenna tune. Please ensure that SWR measured at three frequencies (118, 127 and 136 MHz are good choices) is less than 1.3 if possible. You want this number to be as small as possible. This number indicates how much of the transmitters power is being absorbed and radiated by the antenna. Any power not radiated is reflected back towards your transmitter where it may enter your aircraft's power supply grounds and audio system. A low SWR number also indicates that your antenna will perform well during reception.

The most common reason for bad SWR in an aircraft is an unsuitable, missing or too small ground plane for the commonly used monopole antenna,

TX signal delay

The audio signal transmitted is automatically delayed by 8mS (milliseconds) using a digital delay chain. This delay is short and cannot be noticed via the sidetone by the pilot. The purpose of this delay is to help break potential RF feedback loops by destroying the required time relationship between microphone signal and transmitted signal to favor oscillation.

Note that this does not completely eliminate feedback effects in all cases. The best way to prevent feedback is to eliminate the causes caused by poor or compromised installations.

RS232 and CAN bus communication protocols

The protocols used to communicate with the V16 are available to third party developers that would like to integrate the V16 into their systems.

Please contact MGL Avionics (info@MGLAvionics.co.za) to obtain the latest protocol documentation.

Setup menu

The setup menu's exact visual form cannot be described here as it depends on the type of control system (Head or EFIS).

However in principle it is similar across all platforms and consists of a text created by the radio once the menu system has been activated.

The text represents one menu item which can either be selected or changed depending on its type.

The list here shows all the available menu items and typical texts you can expect and explains the settings.

Your controller will provide a means to activate the menu. Typically this would be pushing a button or some action on a touch screen or similar.

Menu items

VOX Level: 5 VOX Bypass VOX Disabled	Set the level of the VOX intercom microphone noise gate. Values from 0 to 10 can be selected. Bypass opens the microphone (no VOX function). A value of 10 would require the highest sound level at the microphone for the VOX to open. Note: Your microphone gain adjustment affects this setting. Ensure your gain setting is correct for your microphone type. VOX disabled: Your Intercom input has been selected as intercom switch.
Pilot Mic gain: +0db	Microphone gain for the pilot microphone. A wide range of gains can be selected. Standard aviation headsets tend to be around +0db.
PAX Mic gain: +0db	Microphone gain for the passenger microphone. A wide range of gains can be selected. Standard aviation headsets tend to be around +0db.
AUX normal level 0db AUX input off	Input gain adjustment for the AUX input. Also used to select the AUX input to be "off". Note: if not using the AUX input it is highly recommended to switch the input off as it can pickup interference due to its high impedance nature.
AUX mute level -12db AUX mute off	If AUX mute off is selected, the AUX input follows the gain selected above. If a mute level is selected the AUX input will be selected to that level if any of the two microphone circuits is active. In other words, if you for example are using the AUX to

	play music, the music can be set to a lower level if the pilot or passenger is talking over the microphone. Note: AUX signal is never transmitted regardless of any setting.
TX audio: Use VOX TX audio: No VOX	Select if you would like the microphone to be open for the duration of the transmission or subject to the VOX noise gate system.
No TX if RX is active TX if RX is active	Select if you want to prevent TX when RX is currently active on the active frequency as determined by your RX squelch setting.
TX Sidetone ON TX Sidetone OFF	The TX sidetone is the sound routed to your headsets when you are transmitting. The audio signal here is derived from demodulating the actual transmitter output signal. You can switch this off. This may be desired for example if you are using the V16 as base station and are using a speaker. The speaker should be silent when you are transmitting.
TX Power 5W TX Power 10W	The V16 can be selected to use a lower TX power for applications needing to reduce current consumption during transmission or that may suffer from RF feedback issues due to strong transmissions in a compromised installation.
CAN Bus: COM1 CAN Bus: COM2	Note: This entry will only be shown in units where addressable CAN bus is enabled at the factory. Select here if the V16 should be addressed as COM1 or COM2 if connected via the CAN bus. Note: if you change this setting from a CAN bus controller the communications will immediately stop as the change takes effect immediately. Also please make sure you only connect ONE V16 to the CAN bus at any one time. See notes below.
Intercom switch is mike Intercom switch is playpack	Select if you would like to use the intercom switch input as a microphone activation switch (this option disables the VOX) or if you would like to use this input as playback request for last RX.
Version	Shows the firmware type and version
Serial	Shows the serial number of the V16

Factory default	Allows you to set all settings to factory default after confirming the choice.
-----------------	--

CAN bus addressing

The CAN bus can accept one or two V16 transceivers. These need to be identified as either COM1 or COM2.

You perform this selection in the setup menu.

If you perform this selection from a connected CAN bus control head communications from the head to the V16 will stop immediately as the new assignment is active.

Change the target V16 on the controller to the new assignment after you changed it on the V16 to re-establish communications.

Note: In order to protect against accidental changes of the CAN bus addressing you have 30 seconds after applying power to the V16 to change this setting. Any attempt to change this setting after the initial time window will be rejected.

Note: Only change this setting if you have ONE V16 connected to the CAN bus. If you have two V16 transceivers connected, plug in the first one, assign the address (if required, the default is COM1 anyway), then unplug it and plug in the second one and assign it as COM2. Then you can plug in COM1 and they will then behave as two independent systems on the CAN bus.

Note: Keep the CAN bus dedicated to the V16(s) and any of its control heads separated from any other CAN bus in your system. The CAN bus for the V16(s) is private to these devices. Do not share the same CAN connection with an EFIS CAN bus or any other CAN bus you may have in your aircraft.

VSWR Antenna checks and tuning

The V16 transmitter provides a built in VSWR meter. To enable this device, please enable the TX Information option of your display device. If enabled, you will be presented with the forward power measurement at the transmitter output as well as the ratio of forward power to reflected power from the antenna.

An antenna with an ideal behavior will look like a 50 ohm resistor to the V16. This results in a VSWR reading of 1.0 which means no power is reflected.

Real antennas rarely get very close to this. As the airband frequency range is relatively wide an antenna will be typically tuned to mid band (around 127Mhz) and will provide a good match at that frequency but at lower or higher frequencies the match will get worse. Some antennas may be designed to provide a more even match over the range using various techniques.

What is a good antenna match ?

A typical good match is below 1.3 at the tuned frequency (preferably even lower) and not worse than 1.5 at any other frequency.

It is usually sufficient to test at three frequencies: 118.000, 127.000 and 136.900 MHZ.

Literature suggests that VSWR readings of up to 2.0 are acceptable. However we would strongly advise to aim for much better matching. The reason for this is not transmitter protection but what happens with the power that is not radiated by the antenna. This power, which can be significant tends to enter your aircraft's electrical wiring via the power supply ground of the V16. Here it can provide significant issues to other electronic devices in your aircraft, in bad cases even leading to damage.

A secondary effect of reflected power can affect your V16's intercom system – reflected power contains the audio modulation you are transmitting and this can find its way into your microphone leads and audio wiring. This sets the system up for RF feedback which can cause distortion, howling or echoing during transmit.

Your transmitter is designed to operate at full power up to an VSWR of 4.0 – above this the transmitter will start reducing power to protect itself. The maximum power reduction is 50%. If your V16 is set to 5W TX power then no power reduction takes place as the transmitter will survive even a very bad mismatch.

Reasons for a bad VSWR:

- a) Incorrect antenna cable (such as 75 ohm cable instead of 50 ohm).
- b) Non-existent or incorrectly dimensioned antenna ground plane (for typical monopole antennas).
- c) Faulty cable wiring to connectors (open or short circuit).
- e) Unsuitable antenna type, bad mounting location with nearby metal interference or antenna not designed for VHF frequencies.
- f) Faulty antenna (this should be quite rare, just mentioned for completeness).

Tuning antennas

This is typically done by adjusting the length. Shortening the antenna moves the tune to a higher frequency. If you tune this way – tune in very short segments (0.5cm or less) and observe the result.

Mechanical dimensions

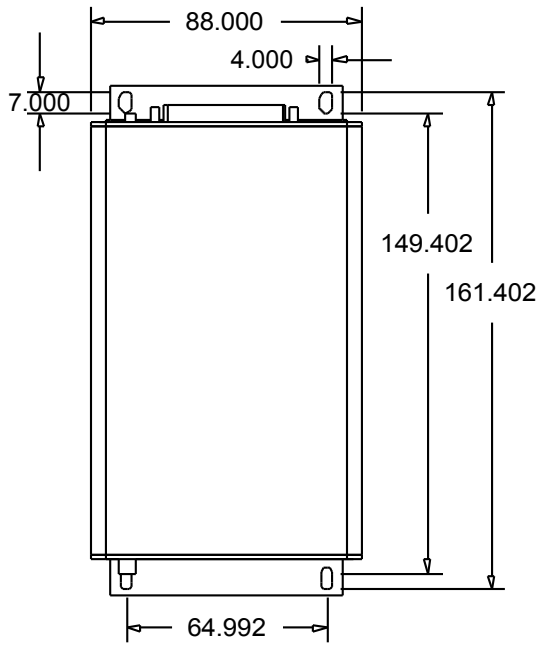

Dimensions +/- 0.25mm tolerance

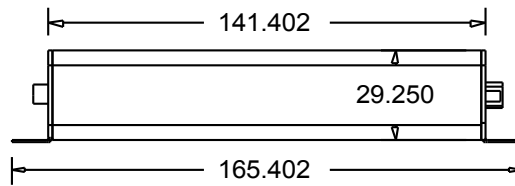

Materials

Body: Aluminum extrusion

Flanges: Stainless Steel, 1mm, Fasteners Stainless Steel.

Labels: Vinyl